

ITEMS		
REFERENCE	DESCRIPTION	MATERIAL
A	STONEMEC SUPPORT CHANNEL	STAINLESS STEEL
B	M12 CHANNEL NUT	STAINLESS STEEL
C	8.0mm BACKING PLATE	STAINLESS STEEL
D	M12 CHANNEL BOLT	STAINLESS STEEL
E	12.0mm WASHER	STAINLESS STEEL
F	M12 PIN LOCK NUT	STAINLESS STEEL
G	M12 PIN	STAINLESS STEEL
H	30.0mm VENEER	STONE
I	HILTI M8 x 55 HUS-HR	STAINLESS STEEL
J	M6 x 65 COACH SCREW	STAINLESS STEEL

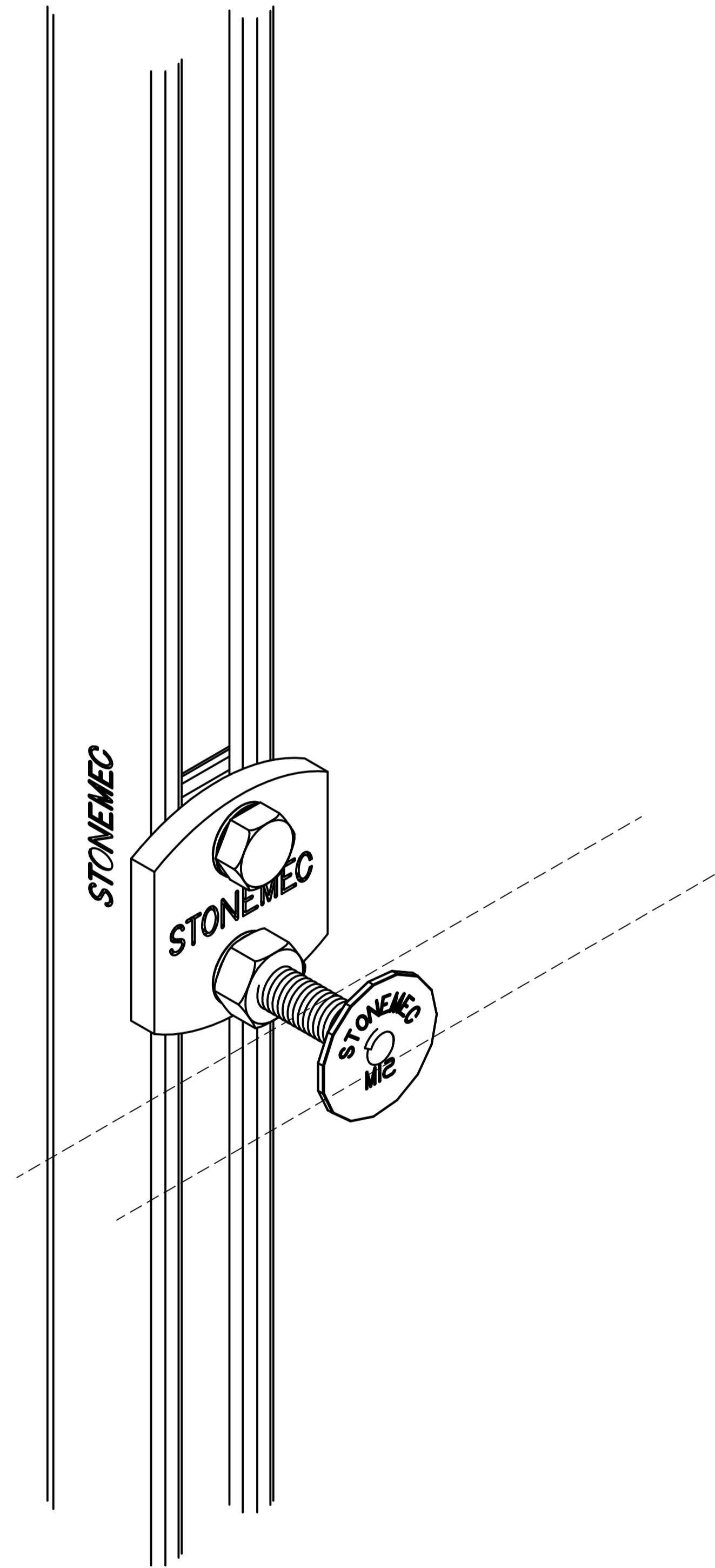

A 01-11-2014 DRAFT ONLY
 REV DATE REASON
 AMENDMENTS



TH CONSULTANTS Ltd
 Civil and Structural Engineers

39 Latimer Square PO Box 13 117
 Ph 03 366 1502 Christchurch 8141
 Fax 03 379 4658 New Zealand
 www.thconsultants.co.nz info@thconsultants.co.nz

STONEMEC SUPPORT SYSTEM

M12 CLIP

Scales
 AS SHOWN
 Drawn
 G.W.P.

s1.2A
 JOB No.
 4022-03